

IMPORTANT! READ THESE INSTRUCTIONS BEFORE USE

Static Installation Components

If you have purchased a controller for permanent static installation in the store, you should receive the following components:



Thermo-Humidistat Controller with power supply lead fitted with Type G plug and control output lead fitted with connector



Additional or alternative components that may be included if you have ordered them:

- Automatic fan starter/thermal overload unit (for the first fan)
- Automatic starter with time delay and connecting lead (one for each fan after the first one)

Important: Check to ensure that each fan starter is of the correct phase and overload range for the fans being controlled

Portable Board-Mounted Components

If you have purchased a portable board-mounted controller, you should receive the following components:



Board Mounted Thermo-Humidistat Controller with power supply plug and socket set and output plugs and sockets for up to 5 fans

Important: Check to ensure the input and output sockets are of the correct phase for the fans being controlled

Introduction

The Thermo-Humidistat Controller assists with crop temperature and moisture reduction during ventilation of stored crops and can work with a range of fan sizes in different storage applications. It operates by measuring the temperature and humidity of the air and turns the fans on or off depending on what temperature and humidity values have been set by the user. The user sets the controller so that the fan(s) only turn on when air is available that is likely to benefit the stored crop by cooling or drying it. There is an override for manual fan operation.

Each Thermo-Humidistat can operate more than one fan. The first fan is operated using a fan starter. Additional fans are operated using a starter with a time delay. The Thermo-Humidistat also acts as a store monitoring device, with alternating air temperature and humidity displaying on the unit.

The Equipment

Static Unit

The basic unit comprises the controller with fan starter connection cable and dry bulb temperature and digital humidity sensors. Fan starter/contacter units may also be supplied (see pictures above)

Portable Board-Mounted Unit

The basic board unit comprises the controller with up to 5 fan starter/contacter units to suit either 1 phase or 3 phase supply are fitted to the board. Each controller has an input connector complete with plug supplied, normally of 32Amp rating, and each starter has its own output connector of 16Amp rating complete with plug.

Important: Do not attempt to open the container that houses the digital humidity sensor. There are no user serviceable components inside this unit. If this unit is opened there is a very high risk that the sensor will be permanently damaged. The unit warranty will be void if the container housing is opened.

Installation

Important:

- This unit must be installed in compliance with the 17th IEE regulations.
- It is the purchaser's responsibility to ensure that there is an adequately rated power supply to the controller and suitable electrical connections available on site.
- It is the user's responsibility to ensure that all appropriate safety precautions are followed during the installation and use of the controller.
- A qualified electrician **must** install and check the controller and fan starters before use.
- The power supply to the fan(s) and to the controller must be disconnected before any connections or alterations are made.
- Appropriate safety signs should be fixed onto each fan being controlled. For example: "Warning. Automatic Control. Motor may start unexpectedly. Disconnect power supply before working on any part of the system."
- The Electricity at Work Regulations 1989 require that any electrical equipment that has the potential to cause injury is maintained in a safe condition.
- **Please Note: This unit has an IP rating of 44 and is unsuitable for installation outdoors.**

Thermo-Humidistat Controller Ins

Locating the Controller

- Position the unit out of the wet and away from direct sunlight. The controller must be under cover in a position where the sensors can receive average ventilation. This means not too close to ventilation fans or high velocity airstreams from the exterior of the crop store or fan house, so that the air temperature and humidity measured is representative of the air being used to ventilate the crop.

Electrical Installation of Static Unit

- Wall mounting points are located inside each starter and the controller enclosure.
- The static Thermo-Humidistat control unit requires a single phase power supply to operate.
- Connect the power supply to each fan starter and fan as per the diagram inside the starter enclosure. An earth and neutral connection is provided inside the single phase unit; an earth connection is provided inside the three phase unit. All entry points to the unit must be made in accordance with the regulations, using appropriate glands.
- Before connecting any power supply, ensure the overload in each starter has been set to the correct rating for the fan.
- Locate the controller output lead into the left hand side socket of the first starter. Use the connector leads supplied to link the additional starters for each fan after the first one.
- If using Martin Lishman Pile-Dry Fans, switch the controller to manual and ensure the fan impellers are spinning anti-clockwise when viewed from above.

The basic configuration of the installation of the Thermo-Humidistat controller and the fan starters is as follows:

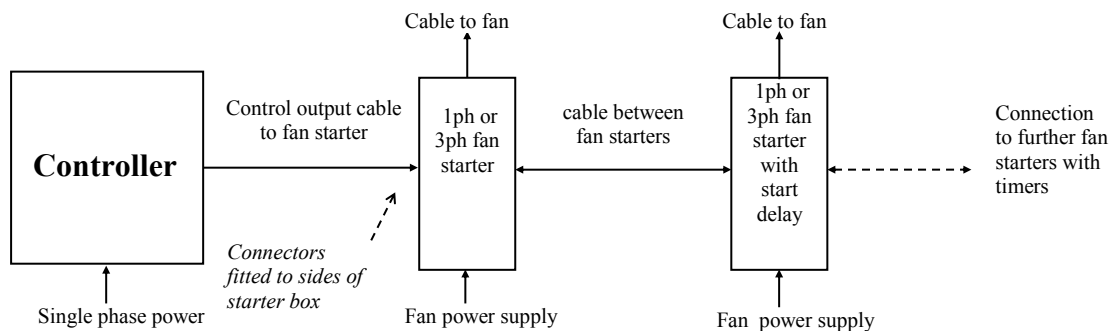

The actual location and arrangement of the components will depend on the existing electrical set-up in the building, and should be agreed between the purchaser and an electrician. Some typical arrangements are as follows:

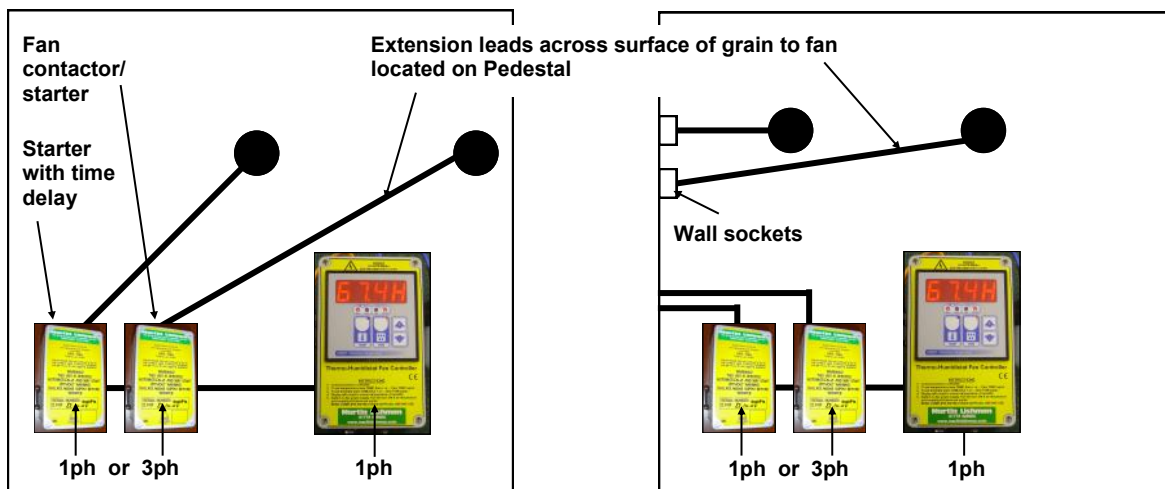

Electrical Installation of Portable Board-Mounted Unit

- Connect the unit to a suitable power supply using the plug supplied and suitable cable.
- Connect the fans to the plugs supplied using suitable cable.
- Plug the fans into the sockets on the board.
- Before connecting any power supply, ensure the overload in each starter is set to the correct rating for the fan.
- If using Martin Lishman Pile-Dry Fans, switch the controller to manual and ensure the fan impellers are spinning anti-clockwise when viewed from above.

The typical arrangement after connection is as follows:

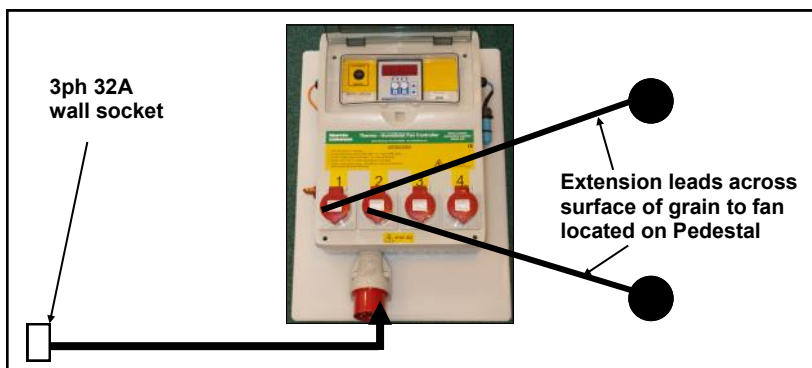

Recommended electrical and socket requirements for connection of a board-mounted controller to Pile-Dry Pedestal Fans is as follows:

Product Code	Phase	Fans	Socket
FCBM01	1	1 x F2 (1.1kW) or 1 x F3 (1.5kW)	13A or 16A (blue round pin)
FCBM02	1	2 x F2 (1.1kW)	16A (blue round pin)
		2 x F3 (1.5kW)	32A (blue round pin)
FCBM03	1	3 x F2 (1.1kW) or 3 x F3 (1.5kW)	32A (blue round pin)
FCBM04	1	4 x F2 (1.1kW)	32A (blue round pin) (not suitable for four F3 1ph fans)
FCBM301	3	1 x F2 (1.1kW) or 1 x F3 (2.2kW)	16A (red round 5 pin)
FCBM302	3	2 x F2 (1.1kW) or 2 x F3 (2.2kW)	16A (red round 5 pin)
FCBM303	3	3 x F2 (1.1kW) or 3 x F3 (2.2kW)	16A (red round 5 pin)
FCBM304	3	4 x F2 (1.1kW)	16A (red round 5 pin)
		4 x F3 (2.2kW)	32A (red round 5 pin)

Please ensure that all power supplies are correctly fused for your system

Storage and Care of the Thermo-Humidistat controller

The unit should be stored in a dry warm place when not in use and the humidity bulb should be protected from dust and dirt. This ensures the bulb does not get saturated or blocked and cuts down on acclimatisation time when it is reused. When in use it is important to keep the humidity bulb clean. Wipe occasionally with a dry, clean non-abrasive cloth

Operating the Thermo-Humidistat Controller

- When the Thermo-Humidistat power is switched on the display will illuminate. For normal use set the controller to *automatic*. Setting the controller to *manual* will ignore the temperature and humidity and turn on the fans.

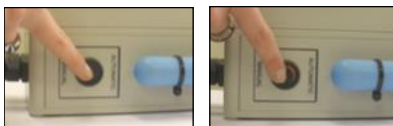

- Set the temperature by pressing [Temp] once. Set.t is shown on the controller panel. Adjust with[+] or [-], (Default is 20°C). After setting press [Temp] again to return to actual display.



- Set the humidity by pressing [Hum] once. Set.h is shown on the controller panel. Adjust with[+] or [-], (Default is 80%). After setting press [Hum] again to return to actual display.



Using the Thermo-Humidistat Controller

Operating the Thermo-Humidistat Controller (continued)

- The controller has a built in differential of 4°C for temperature and 6% for relative humidity. This is essential to avoid the fans being turned on and off too frequently. This means that fans will operate above and below the set point, as in the following examples:

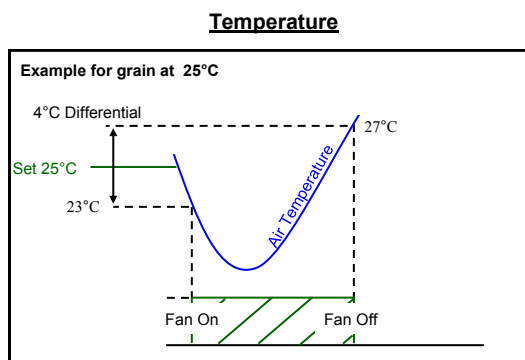

Fan on when air temperature 2°C below set point.
Fan off when air temperature 2°C above set point.
To ignore temperature set to 99°C

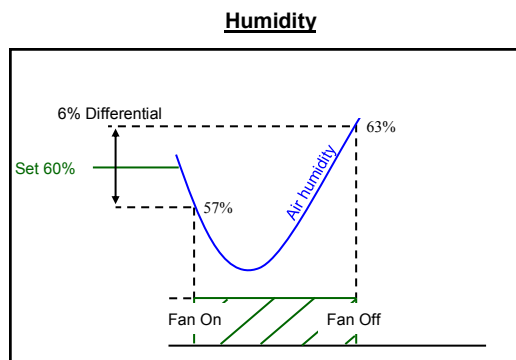

Fan on when air humidity 3% below set point.
Fan off when air humidity 3% above set point.
To ignore humidity set to 99%

- Indicators** - The fan will come on when the Heat LED is lit, indicating temperature conditions are met, and when the Hum LED is lit, indicating humidity conditions are met.

Choosing the Correct Controller Settings

Temperature

For crop cooling the controller should be set below the current temperature of the stored crop. Do not set it too low or many opportunities to cool the grain will be lost. Your best guide is the weather forecast. In the post-harvest period and early autumn, the drop in temperature at night will not be very much, so set the controller about 5°C below your crop temperature. In late autumn and winter, when larger temperature drops are predicted, set the controller to the predicted low temperature. Check the progress of cooling by testing your grain and lower the temperature set point if appropriate.

Humidity

For crop drying the controller should be set below the relative humidity level which is equivalent to the current moisture of the stored crop (refer the HGCA Grain Storage Guide for more information). It is important to make the most of small RH drops, even on less warm days, so limit your RH setting to the equivalent of about 0.5% below the current moisture setting. Check the progress of drying by testing your grain and lower the RH set point if appropriate. If you set your target moisture from the beginning you will miss many opportunities to dry your grain in small increments and there is a strong risk that you will not reach the target.

Setting Recommendations

It is recommended that for cooling that the humidity is set no higher than 75%

For drying grain which has a moisture content above 18%,	set the humidity to 83%
For drying grain which has a moisture content from 16% to 18%,	set the humidity to 72%
For drying grain which has a moisture content below 16%,	set the humidity to 62%

Warranty

The Thermo-Humidistat controller is guaranteed for 12 months from the date of purchase against any defect or malfunction caused by faulty parts or workmanship. To claim under warranty, the complete unit or part should be returned, at the claimant's expense, to Martin Lishman Ltd with a written explanation of the problem. Should there prove to be a defect or malfunction caused by faulty parts or workmanship, it will be repaired or replaced and returned to the claimant without charge. If a warranty claim is rejected, the cost of replacement or repair will be notified to the claimant before any work is carried out.

Any warranty claim will automatically be invalidated if the unit has been modified or internally tampered with in any way. The manufacturers will not cover under warranty damage or faults occurring to the unit which have been caused by inappropriate use or by use not in accordance with the installation and operating instructions for the unit or the fan being used with the unit.

It is the responsibility of the user to ensure that all electrical equipment has been installed in accordance with the relevant regulations, that all appropriate safety checks have been carried out before use and that regular on-going maintenance and safety checks are undertaken.

Under no circumstances will Martin Lishman Ltd re-imburse any costs associated with a warranty claim if these costs have been incurred without agreement in advance.

Under the terms of warranty for the unit under no circumstances will liability exceed the cost of replacement or repair. The manufacturers and Martin Lishman Ltd will not be liable for any consequential or indirect loss suffered by purchasers or users of the unit, whether this loss arises from correct or incorrect use, defect or malfunction caused by faulty parts or workmanship or in any other way. Non-exhaustive illustrations of consequential or indirect loss are loss of profits, loss of contracts and damage to property.